

A Provider's Map

Milestones for a successful CMS submission

CMS Gateways, LLC

11/29/2012 – PQRS DSV (Open) v1.1
5/29/2013 – PQRS DSV (Open & Closed) v1.4
4/14/2014 – QCDR v2.1

Overview: **QCDR** responsibilities

- QCDR tasks
 - CMS submissions
 - Specs
 - Schedules
 - Interface with providers
 - Data source(s)
 - Staff resources

Overview: CMS submissions



**Health Care
Provider**

CMS

CMS Submission

1. Measure
2. Structure
3. Population / Individual
4. PHI Depth

Feedback

Test tool - vetting process
Submission error codes
Post submission Review

CMS Submissions => QCDR workflow

Workflow stages - QCDR

- Obtain patient data from provider
 - Extract & validate
- Compile CMS submission
- Deliver submission
 - Vet, transmit & confirm reception by CMS

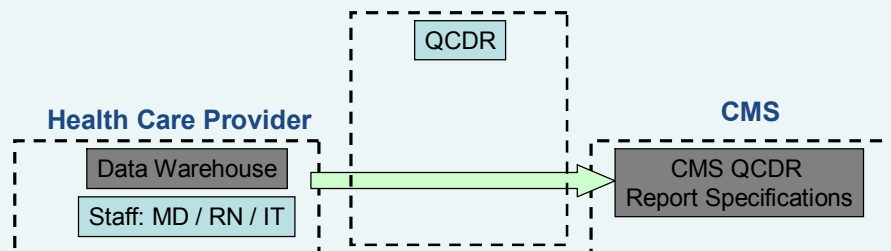

Checklist: QCDR CMS submissions

- QCDR submission considerations
 - CMS submission specs, Data source(s), Staff resources
- Data sources => Provider HIT system
 - Multiple Data sources
 - Many vendors, products, versions, install configurations
 - Multiple facets affect staging and locus of report functions
- QRDA submission compiler options
 - Compare QCDR with Data Submission Vendor (PQRS DSV)
- Common components used for QRDA compiler
 - Legacy data, protocols & standards

What is required for QCDR submissions?

QCDR workflow depends on

1. Specs of the CMS report to be submitted
 - Data Dimensions - Depth / Width: PHI vs. Population
2. Data source(s) used in EP data warehouse(s)
 - Characteristics of provider data source(s) impacts data conversion process
 - Data type, format, structure & accessibility
 - Vendors & configuration(s)
 - Multi-Vendor Integration & Interoperability

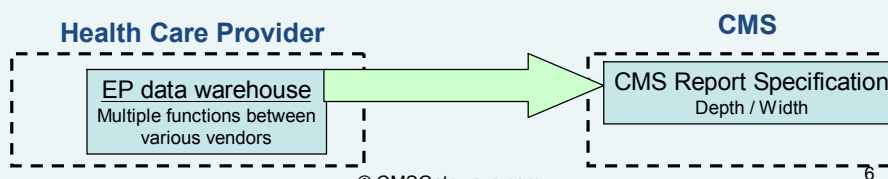

Who's staff is available for QCDR tasks?

Staff resources

- Required for data extraction, report compilation, validation and error processing
- Expertise:
 - Clinical (Quality Metrics)
 - IT (Data Validation, XML integration, Error processing)
- Internal / External / _EHR Vendor/QCDR-HISP/3rd party

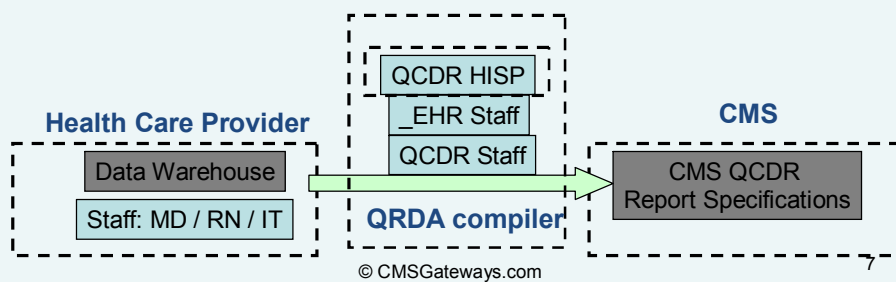

How to minimize regulatory exposure?

- **If CMS rules change, they will change for all QCDRs**
 - Centralize modules for QCDR Submission reports
 - » Eliminate duplication by all QCDRs for same functions
 - » CMS PQRS can be centralized in HISP
 - » HISP = Health Information Service Provider
 - » Standard secure interfaces, defined QCDR compiler functions
 - Enable each QCDR to concentrate on their Specialty Measures

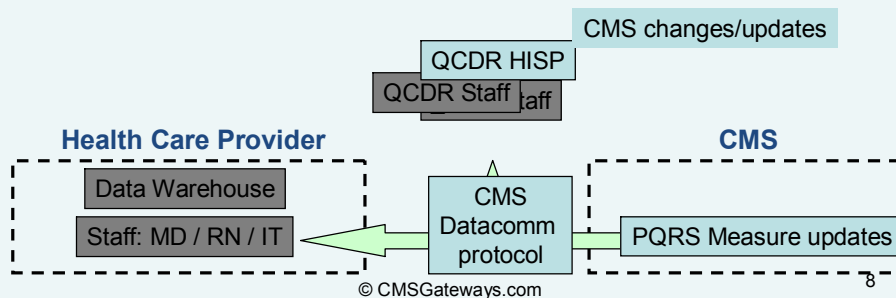

What is optimum way to route errors?

- **Error processing**

- Route errors to delegated organization: Internal / External / QCDR/ _EHR Vendor/3rd party
- Route errors to delegated level of expertise
 - » Strategic error routing and queuing improves throughput

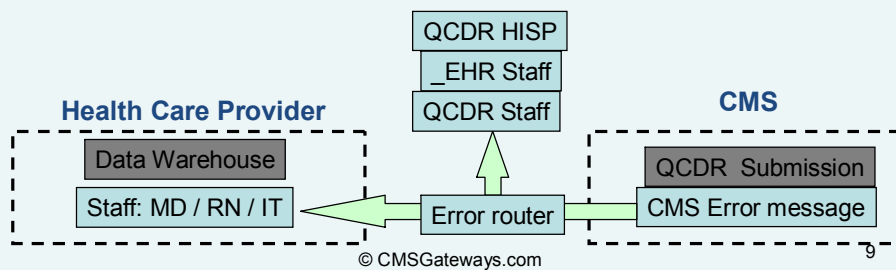

What are CMS Electronic Report requirements?

- CMS Report requirements => Tiered, layered report specifications
 - Report content
 - Report quality

EXAMPLE: CMS – QRDA - PQRS submission specifications

Report Content Specs

- **Measure Specs**
 - Patient Safety
 - Preventive
 - Specialist
- **Clinical Specs**
 - LOINC / SNOMED /
 - CPT / ICD / RxNORM
- **Data Structs**
 - XML / HL7 / CMS / QRDA
 - XPATH notation

Data Quality Specs

1. **TIMEFRAME**
2. Validity
3. Integrity
4. Precision
5. Reliability
6. Timeliness
7. Access
8. Security

What are the QCDR site specific data sources?

Most providers have multiple subsystems

- PM – Practice Management – billing, scheduling
- EHR – Electronic Health Records – clinical records
- DBMS – Database Management System - Organize & correlate data entries

Traditional data extraction – Flat Files w/ data specs or ODBC

- Requires knowledge of internal table layout OF EACH INSTALLATION

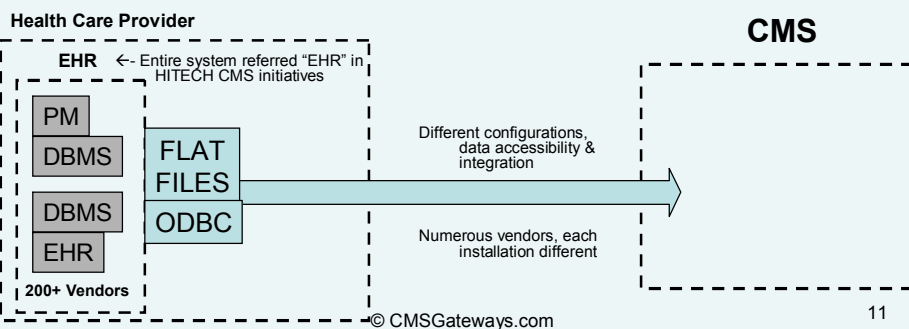

How to eliminate *site specific table details*?

Options to avoid site table internals

- Use external interfaces available in _EHRs
 - Enables data translation between various HIT data standards
 - RepGen – _EHR Report Generation Modules, PP -Patient Portals
 - UIM – User Interface Macros to drive _EHR option screens
- Multiple vendors, installations vary from location to location

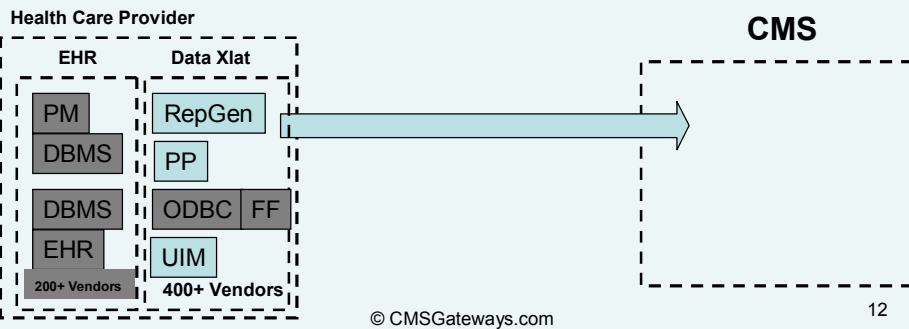

How to merge multiple data sources data?

Options to remove most site specifics

- Utilize components with universal format & transmission
- Enable translation between various HIT data standards
 - IE - Interface Engines (HL7 V2 & V3 messaging)
 - HIE – Health Info Exchange (X.25) (with lookback limits)
- Multiple vendors, installations vary from location to location

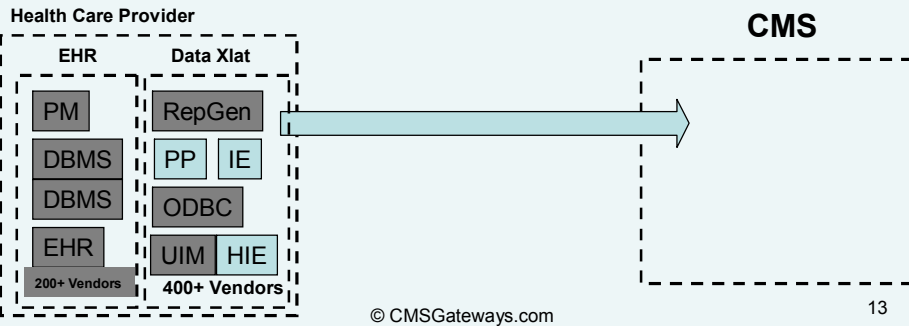

© CMSGateways.com

13

How does the QCDR prepare the data?

CMS reports require extensive data preparation

- Abstract relevant data
- Convert data to applicable standard
- Format according to CMS standards
- Validate that data clusters meet measure specs

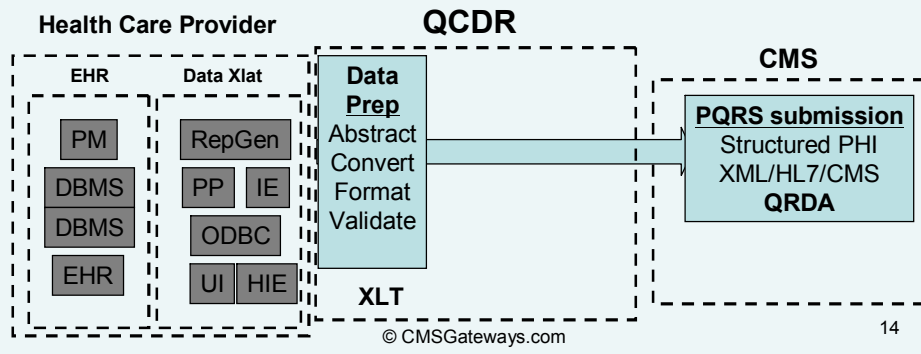

© CMSGateways.com

14

How does QCDR transmit data to CMS?

Transmission chain may require multiple 'hops'

- Must choose between Interoperability options
- Must be flexible as CMS data transmission specs evolve & converge

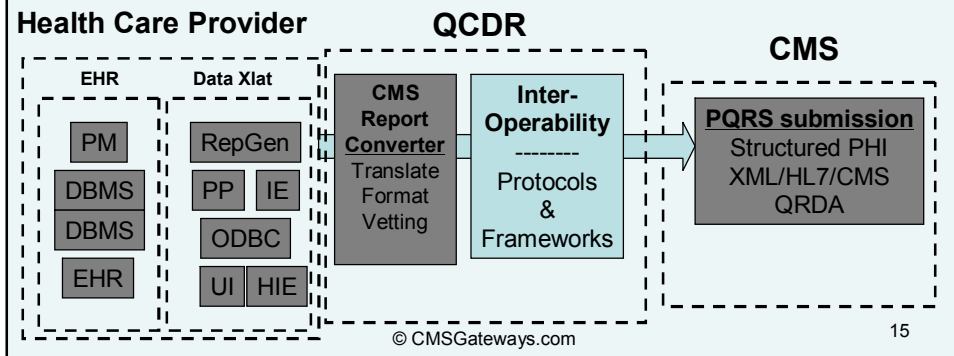

Where is the locus of responsibility for data prep?

Locus depends on

1. The requirements of the CMS report
 - Data Source(s)
 - Structure & depth of data (Population vs PHI)
 - Level of data integration
 - Accessibility - Vendor(s) & configuration(s)
2. Availability of provider resources –
 - Clinical / IT
 - Internal / External / _EHR
 - Bandwidth & Expertise

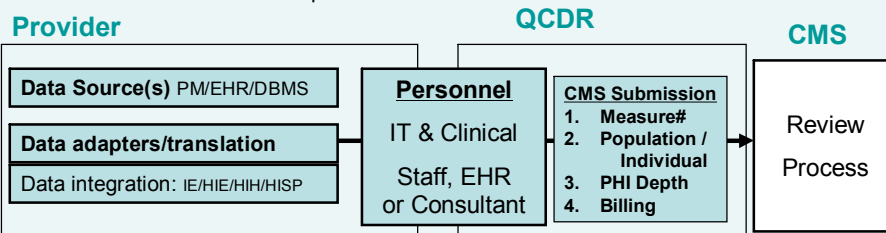

CMS Report considerations
CMS Report – Data Translation Staff

- Staffing options depends on
 - Report Requirements
 - CMS – Data depth, PHI, structure
 - Provider – Review process, Error protocol
 - Internal Staff – Expertise & bandwidth
 - # Data Sources - EHR configuration

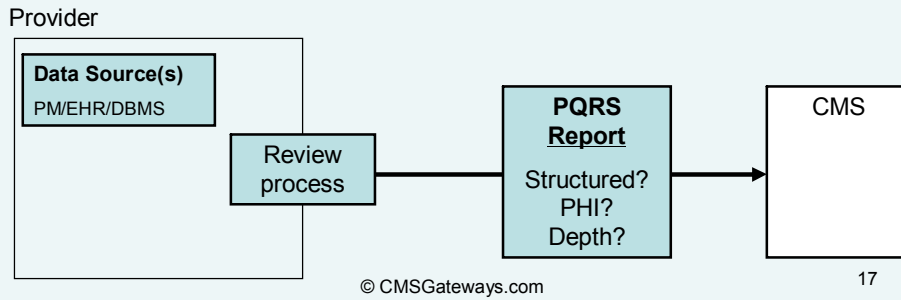

When does provider staff merge data?

Reasons for using this option

1. Provider has detailed CONTROL of report generation & review processes
2. Multiple vendors handles different record keeping
 - PQRS reports require info from both PM and EHR
 - PM – Practice management, EHR – Electronic medical record, IE=>Patient portals

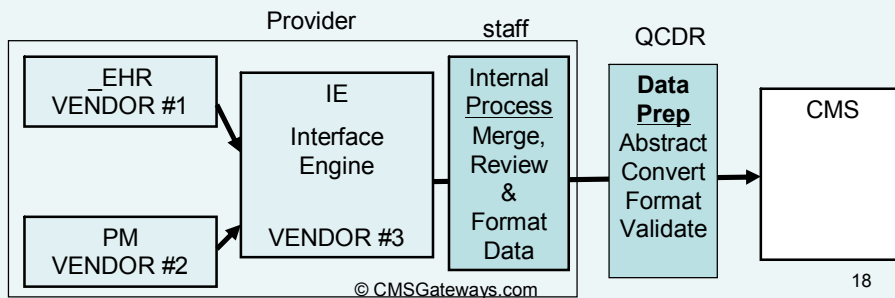

When does QCDR staff merge data?

Reasons for using this option

- Lack of staff expertise mix or bandwidth
- Cannot integrate multiple vendors internally
- Requirement: Extensive review process
- EHR vendor is **NOT** able to generate complete & accurate PQRS reports (*)
 - Provider wishes to have detailed review report processes

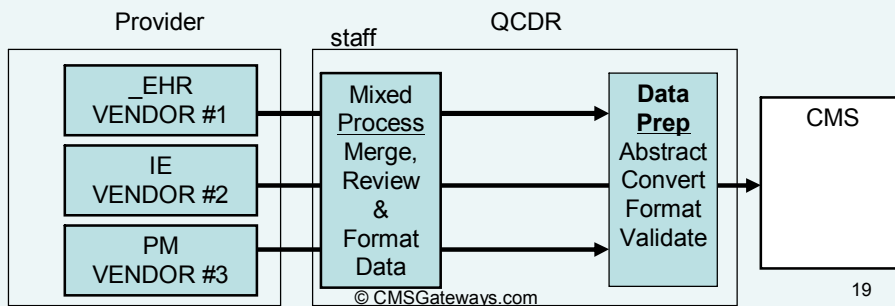

19

When is data merge not necessary?

- Cloud site, or small provider onsite HIT using _EHR DIRECT
 - Assumes **single** vendor handles **all** HIT record keeping
 - PM – Practice management (Front office, billing, appt.)
 - EHR – Electronic medical Records
 - Vendor is able to electronically generate complete & accurate PQRS reports (*)
- Issues: MU2 availability?
- Who is responsible for clinical review process? Tools?

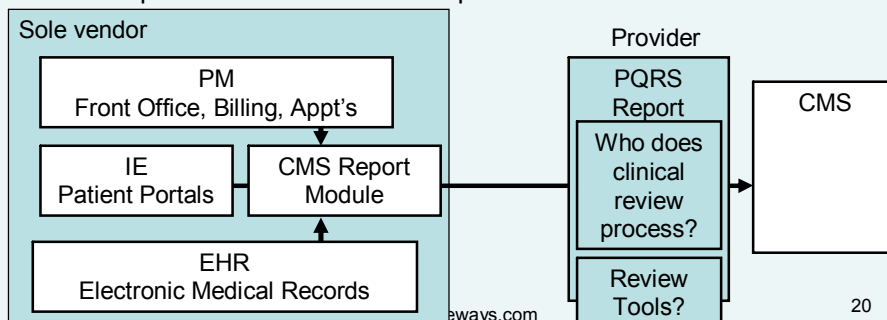

20

What further details are to be encountered?

- Data source types
 - Determined on per provider site basis
 - Some data format(s) convert well to CMS submissions
- Transmission requirements
 - What data transmission methods are used for each data format?

Detail: What type of data translation is needed

- Data source types
 - Determined on per provider site basis
 - Some data format(s) convert well to CMS submissions
- Transmission requirements
 - What data transmission methods are used for each data format?

Example CMS report: PQRS report – data structures

- Target data format: QRDA - Defined in CMS PQRS-EHR spec
- Why did CMS choose HL7 QRDA as design basis?
 - National data standard - HL7 V3
 - Machine and Human readable
 - Person can read C32 with Excel, Word & Browser (with plug-ins)
 - Structured Data integrity
 - Structured data enables detailed review at various process stages

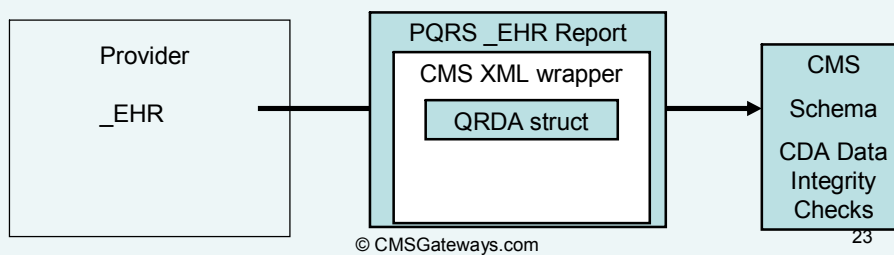

How does Provider EHR export native data?

- EHR's can export many different data formats
- Why should provider aim to use XML format?
 - Most EHR vendors can export C32 data format
 - Vendor support _EHR's required to support C32 by CCHIT
 - Able to select which sections of C32 to report
 - Depending on measure
 - XML Data integrity
 - Structured data enables checks at various stages of process
- Current C32/CCD restrictions by EHR vendor
 - Restrict CCD size for efficiency (to HIE/HIH/HISP)
 - LOOKBACK _EHR Default=1Q,
 - May configure: Size Date range, depth of data

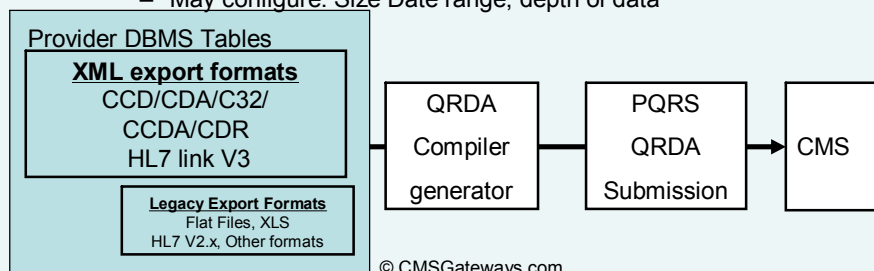

Legacy Data needs map-over/transformation to fit PQRS EHR model

- Usually found in legacy PM (Practice Management) systems
 - PM and _EHR are on separate systems w/ different vendors
 - Interface engines usually support legacy HL7 V2.x feeds
- Legacy data models:
 - HL7 V2.x feed, FF/CSV
 - Does not natively support data integrity checks
 - Requires extensive map-over
- Data translation / mapping to C32 CMS spec is necessary

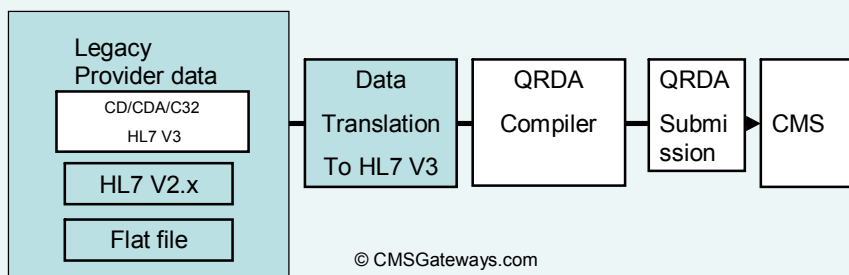

© CMSGateways.com

25

What are live link EHR Input data streams?

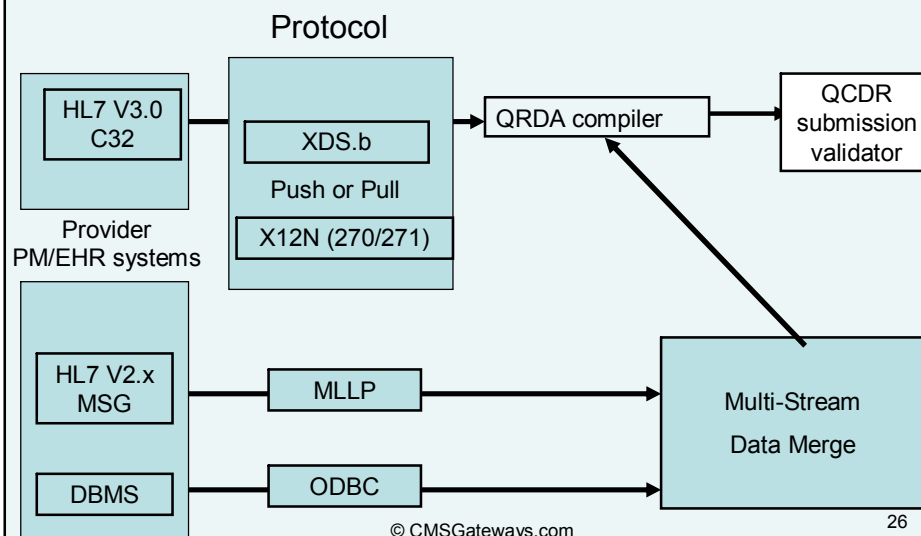

© CMSGateways.com

26

What is the current standard for submission transmission to CMS?

- 2012 QRDA Data Transmission path
HTTPS / User Logon, zip file transfer

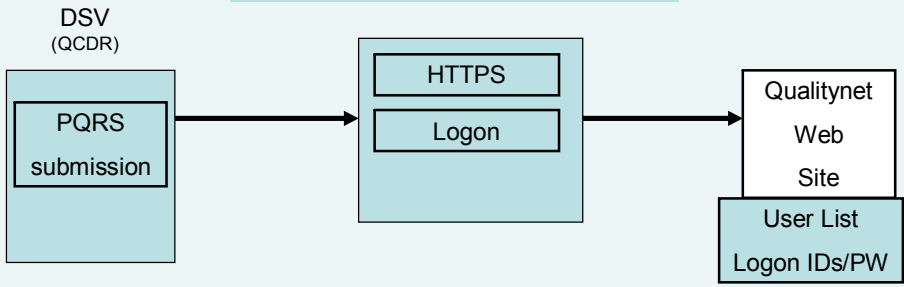

What is a future transmission path option for QRDA data - Option A DIRECT – Secure Email

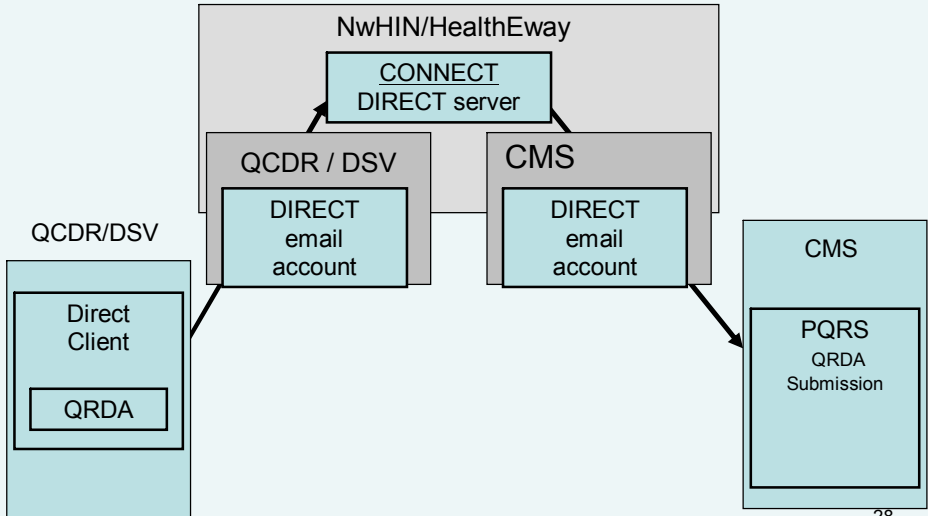

What is a future transmission path option for QRDA data - Option B
Healthway - Connect - NwHIN

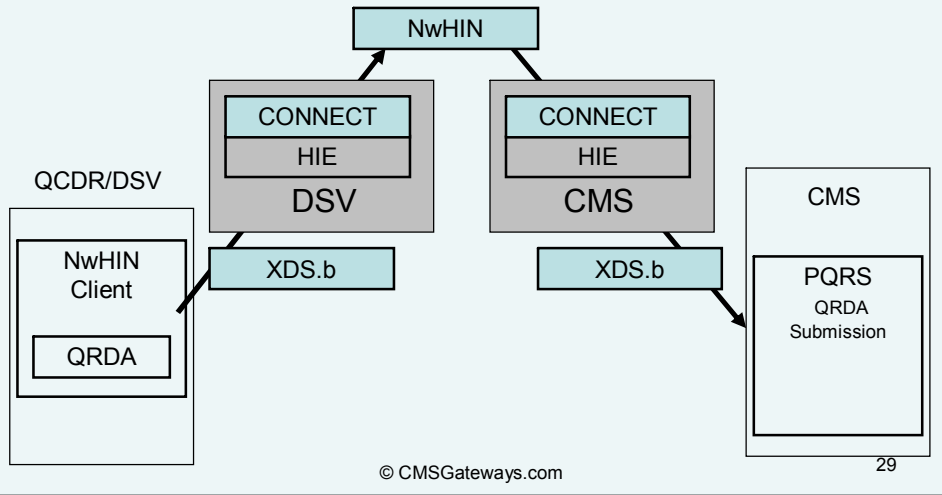

QRDA report generation process
Test / Validation / Logs / Audit trail

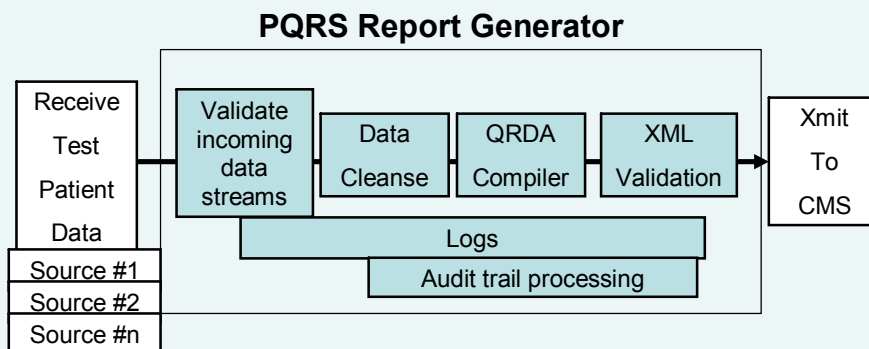

QRDA report generation process HIPPA security

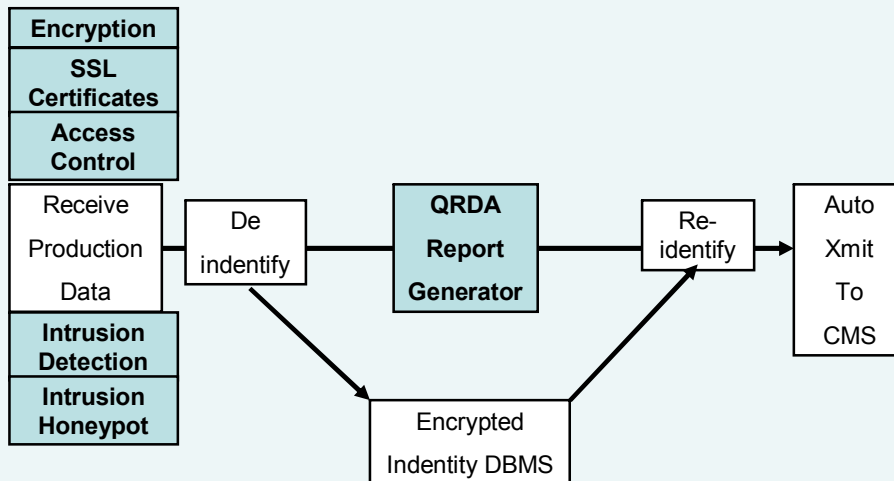

QRDA report generation process Production system configuration

- Separate systems for different stages
 - Security (firewall configuration)
 - Configuration (different glassfish/metro/java configs)
 - Maintenance
 - Scalability

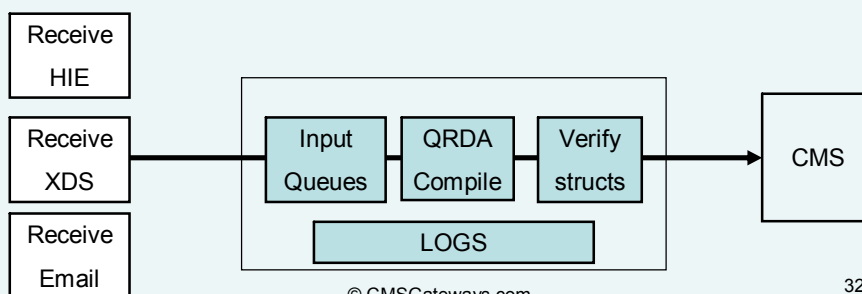

System Maintenance considerations

- Streamlined for Maintainability RAS
 - Queue driven`
 - Monitor processes and interfaces
 - Logs, Signals, Traces
 - Diagnostic tools
 - Increased uptime

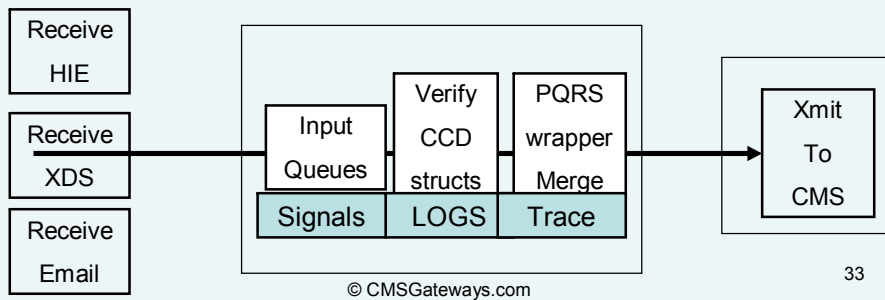

33

CMS Gateways data source matrix

Customer Source data	Protocol / Interface	CMS Gateways Process
HL7 V3.0 CCD/CDA/C32 XML Structure	HIE / XDS.b (w/wo NHIN) Push / Pull	HL7 CDA C32 -> PQRS_EHR
HL7 V2.x Pipe structure	MLLP Network clients	HL7 V2.x -> C32 -> PQRS_EHR
DBMS	ODBC	FF -> C32 -> PQRS_EHR
Static Data Flat file	DIRECT or FTPs	FF ->C32 -> PQRS_EHR

Note: If PM and EHR are on separate systems, different methods can be merged

© CMSGateways.com

34

How do I merge separate data sources?

If PM and EHR systems are with different vendors, Separate Methods can be used depending the support of each vendor support

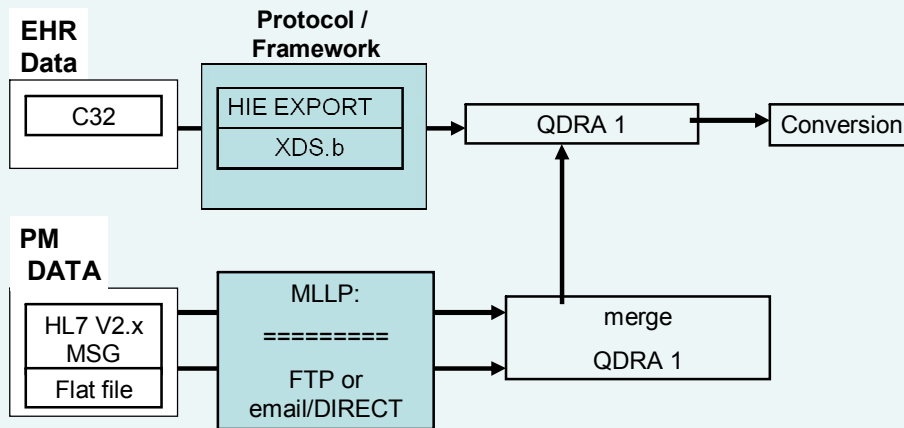

CMS report roadmap (2014/2015)

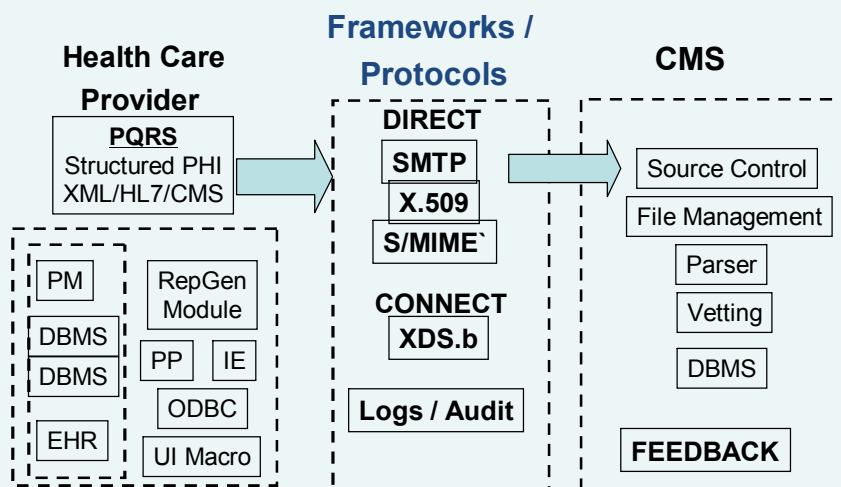

CMS report transmission

- Data pathways for CMS reports must also be forged
 - CMS report transmission chain require multiple stages / 'hops'
 - Interoperability issues, field support are being resolved
 - Report data xmission specs are evolving & converging
 - Vendors must converge on interoperability standard
 - Legislated vs. defacto models
 - Moving target: Few vendors have direct data transmission capabilities

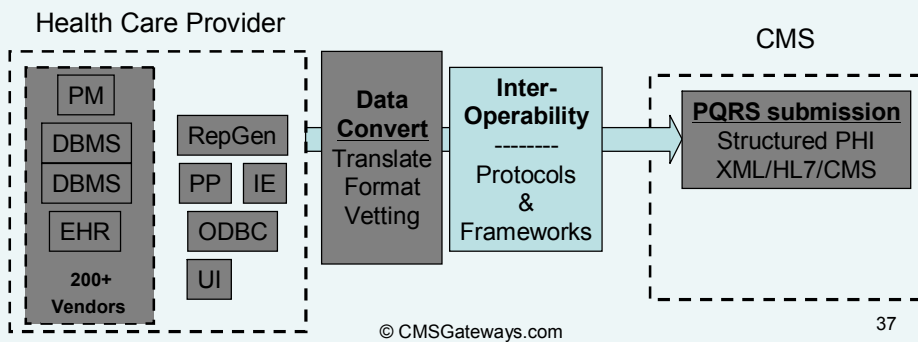

Report Frameworks

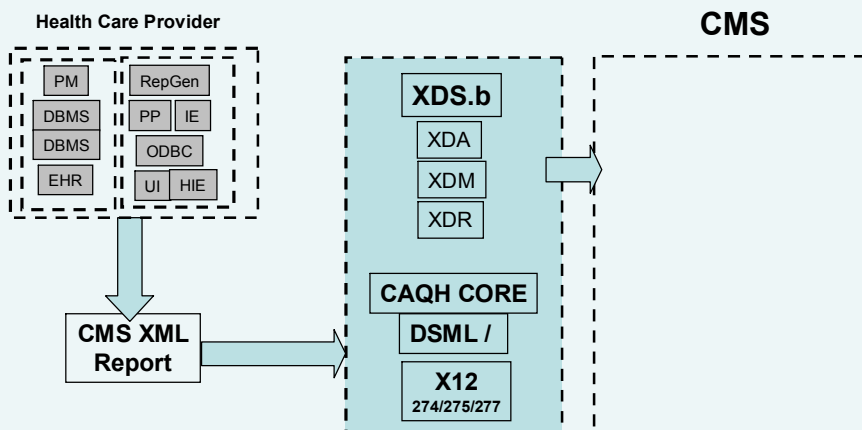

Report – Transport Protocols

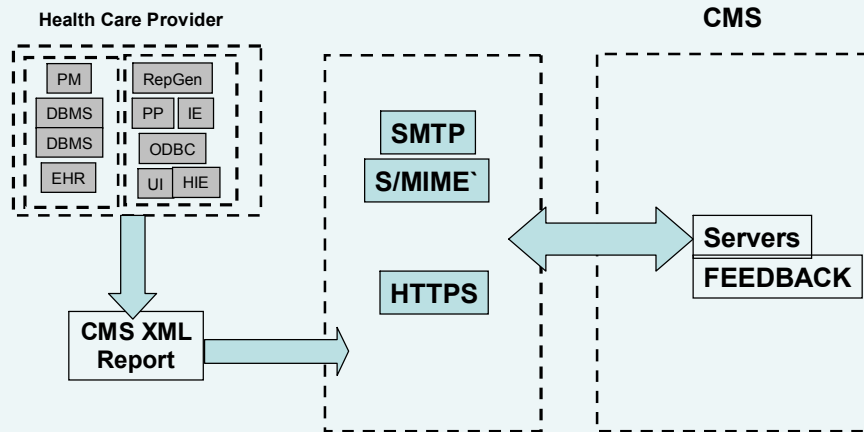

Report transmission Modules

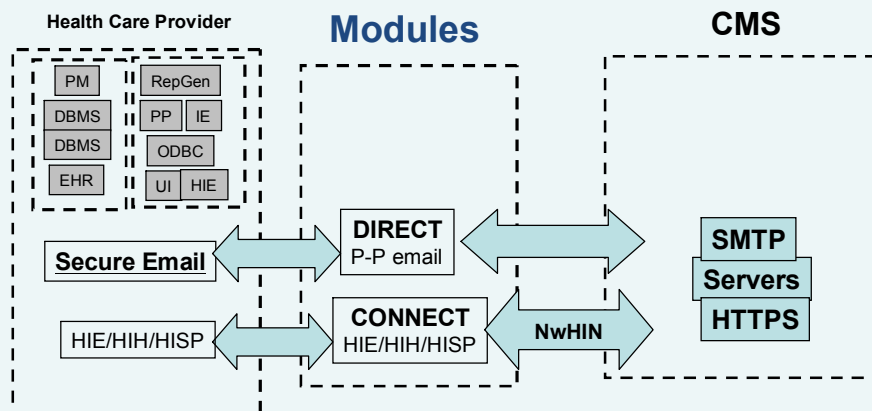

Report - Security

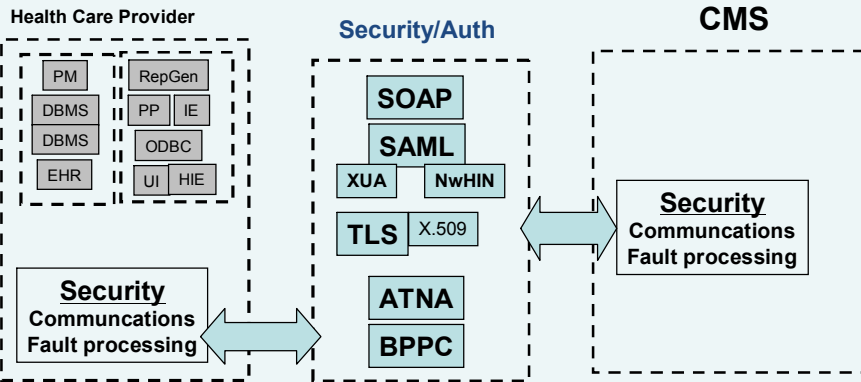

Review CMS Electronic Report workflow



**Health Care
Provider**

CMS Report
 1. Structure
 2. Population / Individual
 3. PHI Depth
 4. Billing

CMS

FEEDBACK SCRIPT

1. Vetting
2. Pre-Submission
3. Submission rejection
4. Incentives
5. Dis-incentives
6. Disqualification
7. Audit(s)
8. Prosecution

Feedback

Example
 SYS BP value
 out of bounds

Review - CMS report generation process

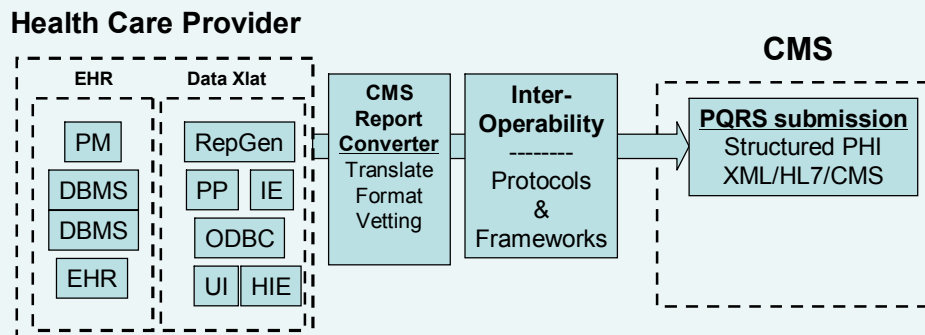

Review: CMS report considerations

- CMS report considerations
 - CMS report specs, Data source(s), Staff resources
- Provider HIT system components -> report generation
 - EHR, Data translation, Report generation & transmission
 - Effects of multiple vendors => Separate functions
- CMS Report generation paths
 - Examples: EHR direct, Closed DSV, Open DSV
- Common CMS report modules & components
 - Legacy data, protocols & standards
 - Digital signature considerations